



Family picnic 2010

INSIDE THIS ISSUE:

FROM SANDY'S DESK 2

I'D LIKE YOUR INPUT CONTINUED FROM PAGE 1 3

ACCREDITATION 2010 A SUCCESS STORY 4

RESIDENT FAMILY PICNIC WELCOME TO NEW FACES FAREWELL TO CHERYL MARTIN STAFF BARBECUE 5

2010 GOLF TOURNAMENT REPORT 6

THANK YOU TO ALL OUR DONORS 7

DONATION OPPORTUNITY 8

I'D LIKE YOUR INPUT

I am thinking about making some changes to the front lobby and would like your input.

Problem:

- Everyday the residents who eat in the Main Dining Room wait in the lobby for the elevators. They sit directly in front of the main doors which are constantly opening and closing. The residents are exposed to cold blasts of air coming in from the outside.
- The congestion in front of the elevators with all the wheelchairs and walkers make it a safety concern especially if we ever had a fire or needed to evacuate the building.
- The reception staff also complain of the cold drafts in the winter and the heat in the summer from the overhead windows.

Proposed Solution:

1. Put up a wall of some kind which would extend from the main door to the pillar on the left, as you walk in to the building. The wall could be glass, glass block (like the dining room washroom walls), frosted glass or wood. It would only be about 7' high and ~13' long depending on the design.
2. Relocate reception to the administrative office and redesign that area with a proper reception desk.
3. The current reception area would be cleaned out and would be used as a staging area for residents waiting to go back up the elevator. I would mount a flat panel TV on the back wall so the residents would have something to watch while they wait.
4. All visitors entering the building will be expected to sign in at the new reception area. This is our current policy but it is difficult to enforce; however with the new wall and reception area, this will be easier to control.

..... Continued on page 3

From Sandy's Desk



Long-term care is extremely busy these days. We have seen more changes this summer than ever before. All the changes are significant and have a lot of implications for residents, staff and management.

There are three changes of note:

1. Long-Term Care Homes Act, 2007 and Regulation 79/10.
2. Long-Term Care Service Accountability Agreement (L-SAA), and
3. Compliance Transformation.

The Ministry of Health and Long-Term Care has stated that “The health care system in Ontario is becoming focused on providing quality, evidence-based resident care and transparent performance reporting”.

Long-Term Care Homes Act, 2007 and Regulations

The new LTCHA and Regulation replace the three previous acts that governed the sector, namely the Nursing Homes Act, Charitable Institutions Act (which governed The Wexford) and the Homes for the Aged and Rest Homes Act. The LTC Homes Program Manual was also eliminated.

There are 10 sections to the Act covering the following:

1. Preamble
2. Residents: Rights, Care and Services
3. Admission of Residents
4. Councils
5. Operation of Homes
6. Funding
7. Licensing
8. Municipal Homes and First Nations Homes

9. Compliance and Enforcement, and
10. Administration, Miscellaneous & Transition.

A copy of the Act and Regulation is available at: www.e-laws.gov.on.ca or at the Admin Office, from 8 am – 4 pm, Monday through Friday. The MOHLTC has provided some funding to the long-term care homes to help with the cost of implementing the new requirements such as increased hours for the dietitian.

Changes with the new Act include an expanded Residents’ Bill of Rights, the establishment of Councils (Every home must have a Resident’s Council and every home may have a Family Council), an integrated interdisciplinary approach to care planning and delivery and continuous quality improvement and utilization review systems.

L-SAA

This is a new service agreement, administered by the Central East Local Health Integration Network (CE LHIN). A copy of the L-SAA is available on our website at www.thewexford.org and is also posted on the public documents pillar in our lobby. This document includes a 15 year license for The Wexford.

Compliance Transformation

This is an entirely new process. In the past we had a Compliance Advisor (CA) who did an annual, unannounced inspection of the home over two or three days. If there were any unmet standards, the CA would issue a report listing the unmet standards which we posted in the lobby with our other public documents.

We were expected to submit an action plan to address each of the unmet standards and the CA

over next page

would then do another unplanned visit to see if we can correct the problem.

The new process involves a team of Inspectors who have received extensive training in the new Quality Indicator Survey or QIS as part of the Resident Quality Inspection (RQI). It is a resident-centered process in that the inspectors will talk to the residents first, will observe processes within the home, will conduct family and staff interviews and review the health records of the residents.

This new process has undergone extensive research by clinical experts to identify Quality of Life and Quality of Care Indicators (QCLIs). There are 136 resident-centered outcome and process indicators in 34 care areas. Each QCLI has a defined numerator, denominator and relevant exclusions. It also uses structured yes/no interview questions.

There are also 12 resident-related inspection protocols (IPs) and 14 home-related inspection protocols as well as 7 mandatory home related IPs.

As you can see, the new process is very different and appears to be rather complex and I have not outlined all the new processes. I am sure, though, that once we have all gone through one inspection process, it will become clearer to all of us.

As always, we welcome the new inspection process and will work with the MOHLTC to ensure that we are compliant with all aspects of the new Long-Term Care Act and Regulations and Compliance Transformation to uphold the Fundamental Principle "...that a long-term care home is primarily the home of its residents

and is to be operated so that it is a place where they may live with dignity and in security, safety and comfort and have their physical, psychological, social, spiritual and cultural needs adequately met".

Sandy Bassett
Executive Director

I'D LIKE YOUR INPUT continued from page 1

Proposed solution *continued*

5. It will be safer for residents at risk of wandering as this is a controlled entrance.

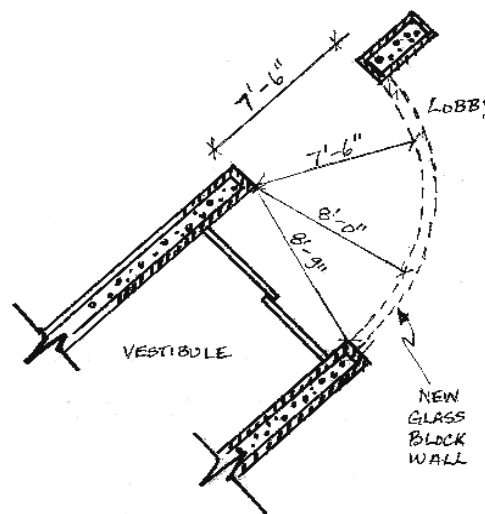

Plan:

1. I have put tape on the floor of the lobby where I propose to put the wall.
2. I have reviewed my plan with our architect and it meets all building code requirements.
3. Seeking input into this change from residents, tenants, staff and family members.
4. I would like to make a decision by September so that something is in place for this winter

If you have an idea, suggestion or concern please do not hesitate to contact me at x225 or via email at sbassett@thewexford.org.



UPDATE

Accreditation 2010 Is Almost Here!

We will be welcoming Janice Dunn and Dorothy Ferguson two surveyors from Accreditation Canada on September 8, 9 and 10th. They will be completing an in-depth assessment of the quality of care that we provide to our residents using a program called QMentum.

The QMentum process provides us with a series of Quality Standards in areas related to Resident Care & Safety, Infection Control and Medication Management. Over the past several months, our internal Accreditation Teams have been reviewing our processes and practices against the standards. This review has confirmed our areas of strength and assisted us in identifying areas for improvement.

When the surveyors are on site, they will be tracing key systems and processes through:

- One on one interviews with residents, staff and family members.
- Holding a focus group with our Community Partners.
- Reviewing supporting policies, reports and documents.

We will receive a debriefing from our surveyors on September 10th. We look forward to positive outcomes and feedback that will provide us with the opportunity to make continuous improvements in support of our commitment to quality care for our residents.

Shelly Gorchynski
Accreditation Coordinator

A success story



Dinu Badescu came to The Wexford in the summer of 2006. He was totally dependent on us to meet all of his needs. With lots of encouragement, excellent care and his determination to

regain control of his life, Dinu slowly began to work towards his goal of living independently in an apartment.

Our Dietitian, Jan worked with us to transition Dinu to oral foods. This was a long process, as he started with pureed, then minced and then regular texture, with frequent assessments by the nurse and Dietitian.

Our Physiotherapist, Vino worked with Dinu three days per week. Dinu was very committed to his exercise program and each day he developed his own routine. He has lost his vision in one eye, however, with the assistance of a magnifier from CNIB was able to use his computer.

Dinu grew stronger and learned to transfer himself using a wheelchair and eventually to take wheel transit and would often go out on trips unescorted. In May 2010, Dinu achieved his goal and was discharged to independent living. He was very happy and often returns to visit and thank all the nurses who worked with him to accomplish his goal.

Esther Spencer
Director of Care

Resident Family Picnic



This year's annual picnic was held on Saturday June 5th, 2010. Strong winds and a forecast of rain seemed to want us indoors. As the morning stretched on, the sun started to appear through the dark clouds overhead showing signs of a beautiful afternoon ahead. Soon after, the aroma of hamburgers and hot dogs filled the air as John Rankin cooked up his own version of a storm.

The event was well attended by residents, family members, friends and volunteers. I would like to thank the staff and volunteers, who helped to make this event a great success.

We look forward to seeing you next year. The date is Saturday June 4, 2011! **Mark your Calendar!**

New this Year!

We will be having a "Country Fair" in the back garden on September 17th at 5:00 pm. The fair will include a campfire, corn roast, hot chocolate, marshmallows, and entertainment. **Save the date and stay tuned for more information!**

Wayne Connelly
Director of Life Enrichment & Volunteer
Coordinator

Welcome to..

Daisy Lin
Food Services Manager



Daisy moved from China to Canada four years ago with a bachelor degree in literature. In 2006 she enrolled in the Food and Nutrition Management Program at Centennial College and two years later graduated with honours. Daisy was the Food Services Manager at Markhaven Home for Seniors before coming to the Wexford. We are pleased to have Daisy on board and look forward to working with her.

We will miss you

Cheryl Martin
Food Services Manager



Cheryl Martin was accepted into the Dietitian Internship program offered through Aramark Canada. We wish Cheryl all the best as she begins a new career as a Dietitian.

Staff Appreciation Barbecue

A Staff Appreciation BBQ was held for all staff on July 8 in the back garden. It was a beautiful day and staff enjoyed the hamburgers, sausages, salad and cake. A number of prizes were given out and Jessie Torres, our casual evening janitor won the day off with pay, a number of staff won free manicures and pedicures as well as our new Wexford mugs.



2010 Golf Tournament Report



Lead Sponsor: Achieva Health-Toula Reppas and Tony Mellos, Mark Dailey citytv and Jeff Bassett

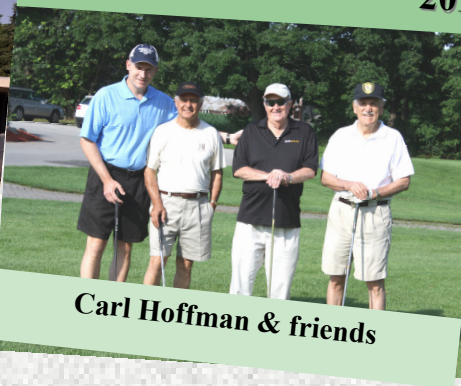

Carl Hoffman & friends



**Dr. Larry & Tommy Bacher
John Bacher and Joe Glinisky**

The Wexford's Fifth Annual Charity Golf Tournament in partnership with Nisbet Lodge, Mariann Home and Valleyview Residence was held on Wednesday June 23, 2010.

131 golfers enjoyed a beautiful sunny day at Remington Parkview Golf & Country Club, which has been the home of our tournament for the past four years. The day kicked off at 8:30 am with Mark Dailey, (the voice of Citytv) opening the tournament. With the addition of our new partners, Mariann Home and Valleyview Residence, we were able to achieve our goal to have a modified shot gun start.

Golf was followed by a luncheon, presentation of prizes and silent auction. The silent auction raised \$4,640. Items included hockey tickets, baseball tickets, a barbecue, and a flat screen TV.

Thanks to our enthusiastic golfers, tournament sponsors and supporters for making our Fifth Joint Annual Golf Tournament successful. This year's Tournament raised a net of \$41,000. Our share of \$14,000 will go towards the purchase of memory boxes for each resident's room.

A special thank you to Mark Dailey - the voice of Citytv, who took the time out from his busy schedule to be with us again this year.

We would like to take this opportunity to thank all our sponsors and supporters for their generosity and commitment to our tournament in support of our seniors.

Lead Sponsor:
Achieva Health:
Toula Reppas & Tony Mellos
Banquet & Golf

Cart Sponsor
Medical Pharmacies: Steve Pearson

Prize Sponsors:
Brimley Medical Centre:
Dr. Tommy Bacher and Dr. Larry Bacher
Precise Parking : Luigi Lato

Tournament Signage:
Graphix Design: David Barker

Hole Sponsors:
Absolute Alliance, Almec Mechanical, Bass Associates, BOMA, Carlon Fire, Corbit Flooring, Complete Purchasing, Exclusive Alarms, Kermerer Group, Mary Ellen Trimble, PointClickCare, SCA and The Wexford Volunteers.

Thanks to all our silent auction sponsors, friends of the tournament and our tenants. We appreciate your commitment to support us each year.

A special thanks to our many volunteers for their enthusiasm and great teamwork.



Bob Robinson, Mary Ellen Trimble, Sandy Bassett & Sue Gilmour

Looking forward to next year - June 22, 2011
Don't miss it! Mark Your Calendar!

A VERY SPECIAL THANK YOU TO ALL OUR DONORS!

The Wexford Residence Foundation would like to take this opportunity to extend a deep heartfelt thank you to all of our donors. We appreciate your continued support:

Absolute Air Systems Ltd.
Absolute Alliance
Accent Building Sciences
Act II Landscaping & Snowplowing Inc.
Adshead, David
Almec Mechanical Services Inc.
Amiro, Burton
Anderson, Angella
Annetts, Wallace
Arfo, Frances
Askew, Ila
Axidata Inc.
Bacher, Larry
Bacher, Tom
Ball & Alexander
Bank Of Montreal
Barker, David
Barker, Tina
Barnes, Kathleen
Bassett, Sandy
Bell, Dorothy
Bellamy, Ruth
Belma Management Ltd
Benac, Nicholas
Bennett, Frances
Bennink, Janice
Bilyk, Keith
Bilyk, Ronald
Bird, Alfred
Bishop, Carolyn
Bishop, Joan
Bishop-Ashe, Amanda
Blake, Verna
Boma Toronto
Boundy, Judith
Bowers, Lillian
Boyd, Carol
Boylan, Phil
Brandt, Cathy
Branscombe, Susan
Brawley, Douglas
Breese, Elizabeth
Brimley Medical Centre
Britton, Barbara
Britton, Edna
Broadlands Community Centre - Older Adults
Brown, Barbara And Alan
Brown, Doreen
Brown, Elizabeth
Brown, Frank
Brown, Jeffrey
Brown, Stephen
Burrows, Viola
Burton, Paul
C2C Construction Ltd.
Cachia, Will
Caires, Emanuela
Campbell, Cynthia
Campbell, Lindsey
Campbell, Martin
Campbell, Prince
Campbell, Wallace
Capra, Stanley
Carestaff Services Inc.
Carlton Fire Equipment Ltd
Carson, Betty
Casuccio, Cecilia
Catalano, Bessie
Chadwick, Rose Marie
Challoner, Carol
Challoner, Evelyn
Chan, Wing Fai
Chapman, Joan
Chipperfield, Evelyn
Chung, Allen
Clark, Louise
Clark, M.
Clarke, Ruth
Codlin, William
Collier, Ethel
Collier, Linda
Columbia Highrise Windows
Comfy Cotton Diaper Service Inc.
Complete Purchasing Services Inc.
Connell, Wayne

Cook, Marilyn
Cooperstock, Ramona
Coppelstone, Donald
Corcar Consulting Incorporated
Corey, Mary
Coutemanche, Brenda
Cowie, Brian
Cronkright Walkins, Joan
Cunningham, Anne
D'mello, Lawrence
D'souza, Colleen
D'souza, Naomi
Da Vinci Flower Shop Ltd.
Daniel, Deborah
Darraugh, Joseph
Darroch, Norah
Davidson, Helen
Davidson, Silvia
Davis, Kathleen
Davison, Marjorie
Day, Audrey
Dee, Roger
Di Blasio, Susan
Dickson, Marjorie
Doner, Dianne
Doney, Doreen
Edgar, Dorothy
Edge, Margot
Eglinton-Bayview Physiotherapy Centre
Ernst & Young Llp
Ferguson, Dorothy
Fetherston, Vivienne
First General Services Ltd.
Fitzakerley, Evelyn
Fitzgerald, Joan
Fletcher, Liz
Foggett, Ivy
Folkes, Dorothy
Foxall, Paulette
Frame, Paterson J.
Frame-Adshead, Kathy
Francucci, Concetta
Fraser, Beryl
Fraser, Constance
Freeman, Caroline
French, Jeannette
Frith, Charles
Frith, Doug
Fullerton, Grace
Futuremed Health Care Products
Gage, Marlene
Galloway, Peggy
Gauthier, Raymond
Genovese, Bobby
George, Claudia
Gholami-Sojarsroudi, Hamideh
Gibson, Paul
Giles, Gary
Gilmour, Elizabeth
Gilmour, Susan
Gilpin, Carol
Gilpin, Edward
Gilpin, Janice
Gilpin, John
Gilpin, Linda
Glover, Don
Goldlist, Bary
Goliss, Diana
Gollings, Helen
Gonsalves, Carol
Grace, George
Graham, Lynda
Gray, Dave
Group 4 Interiors
Guerriero, Perry
Gunn, James
Hanson, Elaine
Hartford, Joan
Hay, Mary Leona
Haydon, Robert
Helliwell, Margaret
Henderson, James
Henry, Margaret
Hernandez, Claudia
Herron, Larry
Hillmount Public School
Hirst, Pearl
Hirst, Stella
Hmt Sales Tax Consultants Inc.
Hobbs, Lillian
Hodge, Kathy
Hodge, Pat
Hodgson, Phillip
Hodgson, Sarah
Hodgson, Shelagh
Hoffman, Carl
Holmes, Margaret

Holroyd, Diane
Hornyak, Betty
Howe, Cheryl
Howe, Denise
Howe, John
Howe, Mary
Howell, Robin
Hub International Ontario Ltd
Hunt, Edna
Hunt, Frank
Image Advantage Inc.
Indus Systems
Interiors By Angela
Invacare Continuing Care Group
Jamal, Al
Jeffery, Ann
Joachimides, Kosta
Johnson, Phyllis
Johnson, Ross
Johnston, David
Johnston, Elizabeth
Johnston, Jean
Johnston, Shirley
Jones, Carol Anne
Joseph, Shantha
Jvc Canada Inc.
Kalajian, Araxi
Kearney, Patricia
Kimura, Rose
Kimura, Tomio
King, Mary
Klincek, Violet
Kling, Erika
Klodt, Gail
Knapton, Barbara
Knapton, Georgina
Ko, Chuen
Kozak, Doug
Kozak, John
Kozak, Walter
Kratz, Rosemary
Kroener, Ilse
Kulmala, Mary
Kurpatov, Irina
Lam, Robert
Langschmidt, John
Lazazzera, Mary
Lenahan, Kim
Lewis, Melina
Lewis, Rose
Locke, Lee
Lockett, Pam
Longworth, Evelyn
Longworth, Jim
Lootsteen, Rienie & Harry
Lorne Miller & Associates Inc.
Loughridge, Nancy
Lundy, Marilyn
Lyn, Hector
Mackenzie, Doug
Macleam, Mildred
Mahdessian, Azadouhie
Maheswaran, Thangaratnam
Malvern Contract Interiors
Mander, Bernice
Manherz, Nicholas
Manina, Paul
Marksfield, Sylvia
Marshall, Helen
Marshall, Jane
Martin, Dennis
Masters, Marilyn
Mathews, Dinsdale & Clark LLP
Maugham, Joy
Mc Health Care Products
Mcburney, Joan
Gunn, James
McCabe, Ellen
McCabe, Irene
McCabe, Shirley E.
Mccaughy, Betty
Mccaw, Dan
Mccolm, Welma
Mccorrey, Patricia
Mccuthcheon, Ron
Mcdonell, Lyn
Mcdowall, Archie
Mceachern, Norma
Mcgregor, Jean
Mckibben, Margaret
Mclelland, Isabella
Mcleod, Alan
Mcloughlin, Nancy
Mcmeehan, Colin
Mcqueen, Barbara
Mcqueen, Grace
Mcvicar, Marian
Medico Pharmacy
Medical Mart

Medirex Systems Limited
Mende, David
Menhenitt, Donna
Mileris, Ramona
Minemoto, June
Missori, Rolando
Mietzko, Joanne
Mochniak, Suzanne
Motion Specialities
Moon, Derek
Moore, Maureen
Morra, Addororata
Morra, Assunta
Morra, Luigi
Morrison, Jean
Mowatt, Boswell
Mowatt, Susan
Natalie, Shirley
Nicholls, Wendy
Nicholson, Joyce
Nielsen, Jean
Norton McMullen & Co. LLP
Oakley, Clarence
Oakley, Mildred
Oleschuk, Karen
Onge, Jeanette St.
Orr, Florence
Ouhingwan, Gilbert
Pallazola, Margaret
Pantar Developments Inc.
Papania, Helen
Pattinson, Gwen
Paul O'connor Funeral Home
Payne, Joan
Peereboom, Elisabeth
Perks, Gerald
Perreault, Carol
Persaud, Cecil
Pesce, Angelo
Porter, Eleanor
Porter, Mary
Powers, Marie
Precision Property Management
Preston, Beverley
Probert, Odeen
Punchard, Edna
Radley, Reta
Raine, Eden
Rainforth, Louise
Ramenda, Violet
Rankine, Anita
Rankine, Doug
Rankine, John
Rapid App Service
Redrupp, Elizabeth
Reid, Len
Reid, Lois
Reid, Robert
Rellinger, Olive
Responsive Health Management Group
Reynolds, Lorraine
Ribes, Katherine
Richards, Edward
Richardson, Edgar
Rivers, Heidi
Roberts, Ruby
Robinson, Verna
Roozen, Linda
Rossi, Debbie
Rothman, Barbara
Roulston, Diane
Rowden, Grace
Roy, Elizabeth
Sadasisvan, Bindhu
Sadler, Patricia
Sayers, Grace
Scarlet-Phipps, Ann-Marie
Schofield, Ross
Scott, Susan
Sebastian, Hazel
Shambrook, Christal
Shan, Robin
Shier, Russell
Shim, Allan
Shoppers Drug Mart
Silloway, Theresa
Simone's New Look Painting & Contracting
Simpson, Gladys
Sinclair, Williamina
Siriska, Colleen
Skarmea, Stavroula
Smith, Anne
Smith, Beatrice
Smith, Connie
Sodexho
Sooknarine, Deokie

Soroc Technology Inc.
Spalding, Donald
Spanjevic, Lilly
Specialty Et Services
Spiegelman, Dorothy
Staff Liaison Commettee
Stafford, Alice
Stearns, Nora
Stephenson, Nancy
Stevens, Helen
Stirling, Carole
Strachan, Margaret
Strome, Linda
Stubbs, Kathleen
Stunell, Michael
Sulek, Marilyn
Swan, John
Tasch, Judith
Taylor, Violet
The Benefits Trust
The Big Foundation
The Wexford Line Dancers
The Wexford Residence Inc.
The Wexford Tea Room
The Wexford Volunteer Gift Shop
Therapist's Choice Medical Supplies
Thomas, Doreen
Thompson, Carol
Tinker, Gordon
Tinker, Nellie
Tomlin, Leanne
Tozer, Sherman
Trace Electric
Trimble, Mary Ellen
Turner, Sharon
Tweedy, Carole
U.S.R.L.
United Commercial Travellers
United Way
Varelas, Helen
Vaughan, Tracey
Veitch, Mary Margaret
Vickery, Donald
Vieira, Lilia
Voituk, Clare
Voudouris, Litsa
Vousden, Patricia
Waller, Janet
Ward, Annie
Watson, Doris
Watson, Steve
We Care Home Health Services
Wenn, Elaine
Wexford Convenience Store
Wheatley, Horace
Wheatley, Jean
Whiffin, Eileen
White, Barbara
Wiley, Catherine M.
Williams, Doris
Williams, Ray
Williams-Owen, Myfi
Wilson, Catherine
Wilson, Douglas
Wilson, Gloria
Wilson, Nancy
Wilson, Rellis
Wilson, Ronald
Winkle, Anita
Wirt, Roseanna
Wright, Lorne
Wright, Sandra
Yeghyayan, Hary
Zaman, Shemin
Zec, Margereete

YES, I WANT TO SUPPORT SENIORS AT THE WEXFORD !

Donations can be made by completing this form and mailing to The Wexford Residence Foundation, 1860 Lawrence Ave E, Toronto, Ontario M1R 5B1. You can also make a donation by telephone, or in person at the Wexford. All donations of \$10.00 or more are tax-deductible and can be paid by cash, cheques, or charged to your Visa or MasterCard.

PLEASE ACCEPT MY DONATION OF: \$ _____

In memory of _____

In honour of _____

A general donation _____

PAYABLE BY:

- Cash Cheque (make cheques payable to Wexford Residence Foundation)
- Visa Mastercard

Card number _____ Exp. _____

Name on card _____

Signature _____ Date _____

ISSUE TAX RECEIPT TO:

Name: _____

Address _____

_____ Postal Code _____

Tel.: _____ Email _____

SEND ACKNOWLEDGEMENT TO:(for in memory or in honour of donations)

Name: _____

_____ PC _____

THE WEXFORD COMMUNICATOR welcomes comments and announcements that would benefit friends and families of residents and tenants at The Wexford Residence Inc., and supporters of the Wexford

Residence Foundation.

Our address is 1860 Lawrence Ave. East, Toronto, Ontario M1R 5B1

T. 416 752-8877, F. 416 752-4350 Toll Free Number: 1-877-807-0810

Website: www.thewexford.org